

INSTRUCTION MANUAL

MCO-5AC

CO₂ Incubator



Note:

1. No part of this manual may be reproduced in any form without the expressed written permission of SANYO.
2. The contents of this manual are subject to change without notice.
3. Please contact SANYO if any point in this manual is unclear or if there are any inaccuracies.

SANYO Electric Biomedical Co., Ltd. All rights reserved. Printed in Japan.

CONTENT

PRECAUTIONS FOR SAFE OPERATION	P. 2
CAUTIONS FOR USAGE	P. 7
Labels on the unit	P. 9
INCUBATOR COMPONENTS	P.11
Control panel and keypad	P.13
Remote alarm terminal	P.14
INSTALLATION	
Installation site	P.15
Prevent contamination	P.16
Installation	P.16
BEFORE COMMENCING OPERATION	
Sterilizing of chamber and attachments	P.17
Connection of CO ₂ gas cylinder	P.18
Automatic CO ₂ cylinder changeover	P.19
OPERATING INSTRUCTIONS	
Set of chamber temperature and CO ₂ density	P.20
UV lamp	P.21
Change of setting of UV lamp ON period	P.22
Key lock function	P.23
Water level sensor	P.24
ALARMS & SAFETY FUNCTIONS	P.25
SETTING OF ALARM RESUME TIME	P.26
ROUTINE MAINTENANCE	
Sterilizing of chamber and attachments	P.27
Removal of attachments	P.28
Filling the humidifying pan	P.30
CALIBRATION	
Temperature calibration	P.31
CO ₂ calibration	P.32
TROUBLESHOOTING	P.33
ENVIRONMENTAL CONDITIONS	P.34
DISPOSAL OF UNIT	P.34
STACKED MODULE	P.35
SPECIFICATIONS	P.37
PERFORMANCE	P.38
SAFETY CHECK SHEET	P.39

PRECAUTIONS FOR SAFE OPERATION

It is imperative that the user complies with this manual as it contains important safety advice.

Items and procedures are described so that you can use this unit correctly and safely. If the precautions advised are followed, this will prevent possible injury to the user and any other person.

Precautions are illustrated in the following way:



WARNING

Failure to observe WARNING signs could result in a hazard to personnel possibly resulting in serious injury or death.

CAUTION

Failure to observe CAUTION signs could result in injury to personnel and damage to the unit and associated property.

Symbol shows;











-  this symbol means caution or warning.
-  this symbol means an action is prohibited.
-  this symbol means an instruction must be followed.



Be sure to keep this manual in a place accessible to users of this unit.

< Label on the unit >
 This mark is labeled on the cover in which the electrical components of high voltage are enclosed to prevent the electric shock.
The cover should be removed by a qualified engineer or a service personnel only.

PRECAUTIONS FOR SAFE OPERATION

WARNING

-  **Do not use the unit outdoors.** Current leakage or electric shock may result if the unit is exposed to rain water.
-  **Only qualified engineers or service personnel should install the unit.** The installation by unqualified personnel may cause electric shock or fire.
-  **Install the unit on a sturdy floor.** If the floor is not strong enough or the installation site is not adequate, this may result in injury from the unit falling or tipping over.
-  **Never install the unit in a humid place or a place where it is likely to be splashed by water.** Deterioration of the insulation may result which could cause current leakage or electric shock.
-  **Never splash water directly onto the unit** as this may cause electric shock or short circuit.
-  **Use a dedicated power source** as indicated on the rating label attached to the unit.
-  **Remove dust from the power supply plug** before inserting in a power source. A dusty plug or improper insertion may cause a hazard.
-  **Use a power supply outlet with ground (earth)** to prevent electric shock. If the power supply outlet is not grounded (earthed), it will be necessary to install a ground by qualified engineers.
-  **Never ground the unit through a gas pipe, water main, telephone line or lightning rod.** Such grounding may cause electric shock in the case of an incomplete circuit.
- Check the gas type and ensure that it is fit for the purpose. Make sure that all pipes are connected correctly and are not liable to become disconnected. Ensure that the gas pressure is set at the specified value. Improper connection of the gas pipe or use of incorrect gas pressure may result in leakage of CO₂ gas. Elevated level of CO₂ gas can be hazardous to health and may lead to asphyxiation and risk of death.**
-  **Never store volatile or flammable substances** in this unit. This may cause explosion or fire.
- Ventilate a room air occasionally when using CO₂ gas for control.** The gas density will increase in an enclosed small room and high level of gas density can be hazardous to health. In addition, avoid inhaling the chamber air directly when opening the door if CO₂ gas is used.

 Si l'appareil est utilisé dans un endroit restreint, le niveau de la densité CO₂ de l'air peut s'élever et peut être nocif aux humains. Évitez d'aspirer l'air provenant de l'intérieur de l'appareil quand vous ouvrez la porte.
-  **Do not insert metal objects such as a pin or a wire into any vent, gap or any outlet** for inner air circulation. This may cause electric shock or injury by accidental contact with moving parts.

PRECAUTIONS FOR SAFE OPERATION

WARNING

 As with any equipment that uses CO₂ gas, there is a likelihood of oxygen depletion in the vicinity of the equipment. It is important that you assess the work site to ensure there is suitable and sufficient ventilation. If restricted ventilation is suspected, then other methods of ensuring a safe environment must be considered. These may include atmosphere monitoring and warning devices. Keep proper gas pressure to avoid gas leak.

 Use this unit in a safe area if using poisonous, harmful or radioactive substances. Improper use may be harmful to your health or the environment.

 Disconnect the power supply to the unit prior to any repair or maintenance in order to prevent electric shock or injury.

 Never expose the eyes directly to UV light as UV light can cause permanent damage to eyes. Never remove cover when UV light is ON (when an optional UV system kit MCO-18UVS2 is installed).

 Hazardous UV light. Do not press door switch.

 Never disassemble, repair, or modify the unit yourself. Any such work carried out by an unauthorized person may result in fire or injury due to a malfunction.

 Disconnect the power supply plug if there is anything wrong with the unit. Continued abnormal operation may cause electric shock or fire.















 If the unit is to be stored unused in an unsupervised area for an extended period, ensure that children do not have access and that doors cannot be closed completely.

 The disposal of the unit should be undertaken by appropriate personnel. Remove doors to prevent accidents such as suffocation.

 Prepare a safety check sheet when you request any repair or maintenance for the safety of service personnel.





PRECAUTIONS FOR SAFE OPERATION

CAUTION

-  **Select a level and sturdy floor for installation.** This precaution will prevent the unit from tipping. Improper installation may result in water spillage or injury from the unit tipping over.
-  **Connect the unit to a power source as indicated on the rating label attached to the unit.** Use of any other voltage or frequency other than that on the rating label may cause fire or electric shock.
-  **When removing the plug from the power supply outlet, grip the power supply plug, not the cord.** Pulling the cord may result in electric shock or fire by short circuit.
-  **Never damage or break the power supply plug or cord. Do not use the supply plug if its cord is loose.** This may cause fire or electric shock.
-  **Do not touch any electrical parts such as the power supply plug or any switches with a wet hand.** This may cause electric shock.
-  **Do not put a container with water or heavy articles on the unit.** It may cause injury if the articles fall. Current leakage or electric shock may result from deterioration of insulation by spilled water.
-  **Do not climb onto the unit and do not put articles on the unit.** This may cause injury by tipping or damage to the unit. When stacking the unit, follow the procedure shown on page 35.
-  **Always hold the handle when closing the door.** This will reduce the likelihood of a trapped finger.
-  **Do not damage the power supply cord.** Stepping on the cord, or processing, pulling, twisting, or binding of cord may cause fire or electric shock by damaged cord.
-  **Never lean or press on the glass or never hit the glass with sharp edge.** Intentional force may cause injury if the glass breaks.
-  **Do not lean on the door.** This may cause injury, current leakage, or electric shock if the unit tips over or door becomes detached.
-  **Always put on gloves at the time of maintenance.** The corners of fixtures may cause injury.
-  **Disconnect the power supply plug before moving the unit.** Take care not to damage the power cord. A damaged cord may cause electric shock or fire.
-  **Empty the humidifying pan completely before moving the unit.** Spilled or splashed water may cause current leakage or electric shock.

PRECAUTIONS FOR SAFE OPERATION

CAUTION

-  **Be careful not to tip over the unit** during movement to prevent damage or injury.
-  **Disconnect the power plug** when the unit is not used for long periods. The deteriorated insulation may cause electric shock, current leakage or fire.
-  **Do not put the packing plastic bag within reach of children** as suffocation may result
-  **Take care of the inside of the outer door.** It may get hot.
-  **Use the power supply cord enclosed with the unit.** Use of an inferior power supply cord may cause electric shock or fire.

CAUTIONS FOR USAGE

1. Install on a sturdy and level floor

Install the unit on a sturdy and level floor and take precaution for preventing tipping over. Inadequate installation may result in water leakage or injury from the unit falling or tipping over.

2. Install in a place not subject to direct sunlight and far from heat sources

Never install the unit outdoor, near windows, or in direct sunlight. And install the unit far from heat sources such as exhausted heat from other equipment. The installation in improper location may result in insufficient performance.

3. Ventilate a room air

Ventilate a room air occasionally when using CO₂ gas for control. The gas density will increase in an enclosed small room and high level of gas density can be hazardous to health. In addition, avoid inhaling the chamber air directly when opening the door if CO₂ gas is used.

4. Setting of 5°C higher than the ambient temperature

The chamber temperature must be at least 5°C higher than the ambient temperature. For example, the chamber temperature is set to 37°C, the ambient temperature must be less than 32°C. Ensure the ambient temperature is within the desired range.

Also, do not place the unit in the direct air flow from an air conditioning system. Cool air from an air conditioning system may cause condensation and lead to possible contamination.

5. Always keep the chamber clean

The condensation may be caused on the inside of the door by spilled water from humidifying pan or opening of outer door for long period. Wipe off the condensation completely with a sterile dry gauze. Especially when the culture medium is spilled, clean and disinfect the chamber immediately. Refer to page 27 "Routine maintenance" for details.

6. Fill the humidifying pan with sterile distilled water

Always use sterile distilled water to fill the pan. The RH PAN lamp on the control panel flashes when the water level is low. Refill the sterile distilled water to the pan when the RH PAN lamp blinks. Note that when low temperature water is poured, the chamber temperature drops significantly. Clean the pan once a month.

7. Always shut the inner door

Shut the inner door completely, and then shut the outer door. If the inner door is not closed completely, even if the outer door is closed, the unit will fail to exhibit its maximum performance.

8. Open/close the doors gently

Ensure you close the doors gently. Robust closing may cause spillage of medium, incomplete closing, or damage of gasket. Also, before opening the inner door, check that the UV light is OFF (when an optional UV system kit MCO-18UVS2 is installed).

CAUTIONS FOR USAGE

9. Use clean containers

The Petri dishes or bottles for culturing may cause contamination in the chamber. Clean the containers before storing them in the chamber.

10. Allow adequate space between the cultures

When storing cultures in the chamber, keep the Petri dishes or bottles containing the cultures sufficiently apart from each other to allow adequate air circulation. Inadequate space may result in uneven temperature distribution and CO₂ concentration in the chamber.

11. Stored materials

Never place acid or alkaline materials or materials that release corrosive gas in the chamber. Such materials can cause failure resulting from discoloration or corrosion.

12. Alarm

Always investigate the cause and fix the alarm condition immediately when the alarm is activated. Refer to page 25 for alarm details.

13. Do not use CAL key

Do not use CAL key on the control panel in normal use. Pressing this key leads the calibration mode. Wrong key operation affects the basic performance. Never touch any other keys on the control panel in the event of pressing CAL key accidentally. After about 90 seconds, the unit returns to chamber temperature display mode automatically.

14. If not used

When the unit is not used, dispose of the water in the humidifying pan and completely remove any moisture in the chamber completely. Check that the chamber is completely dry before closing the doors.







15. Thermal conductivity CO₂ sensor

It is not abnormal that the thermal conductivity CO₂ sensor displays CO₂ density higher than the actual density when the chamber humidity temporarily goes down. And take care of the level of humidifying water because the lack of water affects the CO₂ density.

CAUTIONS FOR USAGE

Labels on the unit

Some warning and/or caution labels are attached on the unit. Following shows the description of such labels.

	This label is on the cover in which the electrical components of high voltage are enclosed to prevent the electric shock. The cover should be removed by a qualified engineer or a service personnel only.
	This symbol means UV caution.
	This symbol means attention or refer to document.
	This symbol means hot surface.
	This symbol means earth.
	This symbol means power switch "ON".
	This symbol means power switch "OFF".

CAUTIONS FOR USAGE

The cautions below are applicable when an optional UV system kit MCO-18UVS2 is installed.

1. Always use humidifying pan and pan cover

The humidifying pan and pan cover prevent the UV light from escaping. Make sure they are installed even if you do not need humidity.

2. Notice of recommended replacement of UV lamp

This unit is provided with a function to notify the recommendation of UV lamp replacement when the accumulated ON time of UV lamp is over about 1,000 hours. The blink of the UV indicator on the control panel recommends the replacement of UV lamp. For the replacement, contact Sanyo sales representative or agent.

E18 will be displayed on the temperature indicator when the UV lamp is burned out. Contact Sanyo sales representative or agent for the replacement.

3. Location of UV lamp

The UV lamp is located in the duct. Take care not to damage the lamp at the time of installation/removal of attachments or humidifying pan.

INCUBATOR COMPONENTS

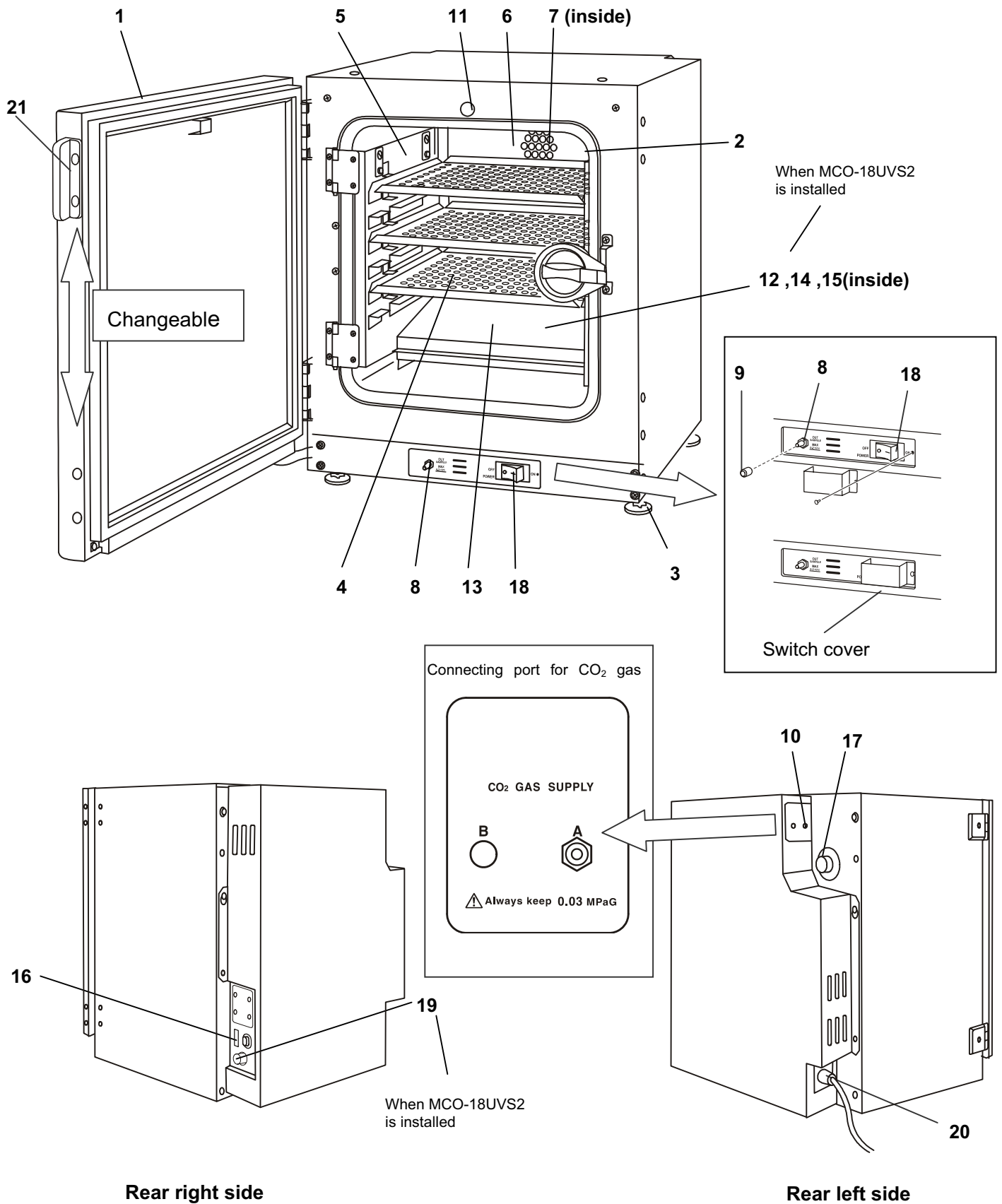

INCUBATOR COMPONENTS

- 1. Outer door:** Sticks to frame with magnetic seal. Door heater is installed in the door panel. The door opening is reversible. Contact Sanyo representative or agent to change the door hinge from left to right or vice versa.
- 2. Inner door:** Made of tempered glass, however avoid excessive impact on the glass.
- 3. Leveling foot:** Screw type for adjusting the height. Adjust the foot so that the unit can be level.
- 4. Tray:** Can be pulled toward you.
- 5. Side support:** Right and left side supports can be removed for disinfection. See page 28 and 29.
- 6. Rear duct:** Flow path for circulating air. Removable.
- 7. Fan (inside the rear duct):** Made from polypropylene resin. Can be sterilized by an autoclave.
- 8. Sample air outlet:** This also functions as an internal gas outlet. Use only a supplied cap(9).
- 9. Sample air outlet cap:** Always attach this cap except at the time of using of sample air outlet.
- 10. Connecting port for CO₂ gas pipe (rear side):** When an optional component MCO-5GC (gas cylinder changeover accessory) is installed, both A and B are available. If MCO-5GC is not used, only A is available. Refer to page 18 for gas cylinder connection. Ensure that the gas pressure is set at 0.03MPaG (0.3kgf/cm²G, 4.3psiG). Refer to page 19 for automatic cylinder changeover.
- 11. Door switch:** Detects the door opening/closing and stops the circulating fan and electromagnetic valve for CO₂ when door is open. UV lamp is also deactivated by door opening (When an optional UV system kit MCO-18UVS2 is installed).
- 12. Humidifying pan:** Use sterile distilled water to fill the pan.
- 13. Humidifying pan cover:** Prevents UV light being exposed to the chamber. When filling the pan, lift the front side and take out the pan. See page 30 for details.
- 14. UV lamp** (When an optional UV system kit MCO-18UVS2 is installed):
Sanyo UV lamp does not generate ozone. Never look at the UV light directly. For replacement, contact Sanyo representative or agent.
- 15. Water level sensor for humidifying pan:** Detects the water level in the humidifying pan. See page 24 for details.
- 16. Remote alarm terminal:** Refer to page 14.
- 17. Access port:** When not in use, cap with the rubber cap on both outside and inside.
- 18. Power switch:** Main switch of the unit. Also functions as an over-current breaker. The switch is covered by a switch cover to prevent the accidental push. To turn on or off the switch, remove the switch cover by loosening the screw. See figure on the right.
- 19. Glow starter** (When an optional UV system kit MCO-18UVS2 is installed): For UV lamp (model; FG-7P)
- 20. Removal Power supply cord**
- 21.Handle:** Outer door handle. When moving the handle from upper to a lower position remove it from original position first, then remove two cups and screws at the lower position and attach the handle there.

INCUBATOR COMPONENTS

Control panel and keypad

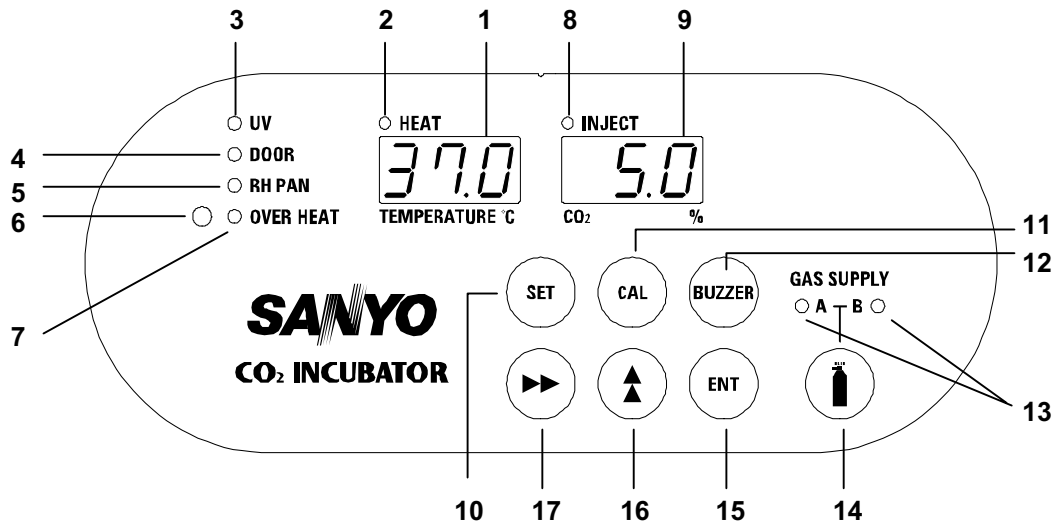

1. **Digital temperature indicator** (TEMPERATURE °C): Normally, this indicator shows the chamber temperature. In the setting mode, it shows the set value of the chamber temperature. If the self diagnostic function detects any abnormality, an error code will be displayed.
2. **Heater lamp** (HEAT): This lamp lights when the heater is energized.
3. **UV indicator** (UV): This lamp lights when the UV lamp is ON. The blink of this indicator recommends the replacement of UV lamp. See page 21 for the details.
4. **Door lamp** (DOOR): This lamp lights when the outer door is open.
5. **Water level alarm lamp** (RH PAN): This lamp flashes when the water in the humidifying pan is less than approximately 0.8 liter.
6. **Upper limit regulator**: This regulator is used to set the upper temperature limit.
7. **Over heat lamp** (OVER HEAT): This lamp lights when the chamber temperature reaches the upper limit set value.
8. **CO₂ inject lamp** (INJECT): This lamp lights when CO₂ gas is being injected.
9. **Digital CO₂ density indicator** (CO₂ %): Normally, this indicator shows the CO₂ concentration in the chamber. In the setting mode, it indicates the set value of the CO₂ concentration.
10. **Set key** (SET): Pressing this key to enter the setting mode, and the digits to be set will flash.
11. **Calibration key** (CAL): By pressing this key for approximately 5 seconds, the unit enters calibration function mode. Also, used to change the UV lamp ON period. See page 31,32 and 22 for the details.
12. **Alarm buzzer stop key** (BUZZER): Press this key to silence the buzzer when the alarm operates and the buzzer sounds.
13. **CO₂ gas supply line indicator** (A/B): The lamp for the supply line currently in use lights up provided that MCO-5GC changeover accessory is installed.
14. **CO₂ gas supply line switching key**: This key to select CO₂ gas supply line is available only when an automatic gas cylinder changeover MCO-5GC (option) is installed. When one CO₂ cylinder is empty, the CO₂ is supplied by the other cylinder automatically.
15. **Enter key** (ENT): Pressing this key memorizes the set value in the controller.
16. **Numerical value shift key** (▲): Pressing this key in the setting mode causes the numerical value to shift. In key lock mode, pressing this key makes key lock ON or OFF.
17. **Digit shift key** (▶▶): Pressing this key in the setting mode causes the changeable digit to shift. Pressing this key more than 5 seconds enters key lock mode. See page 23 for the key lock.

INCUBATOR COMPONENTS

Remote alarm terminal

The remote alarm terminal is located at the rear right side.

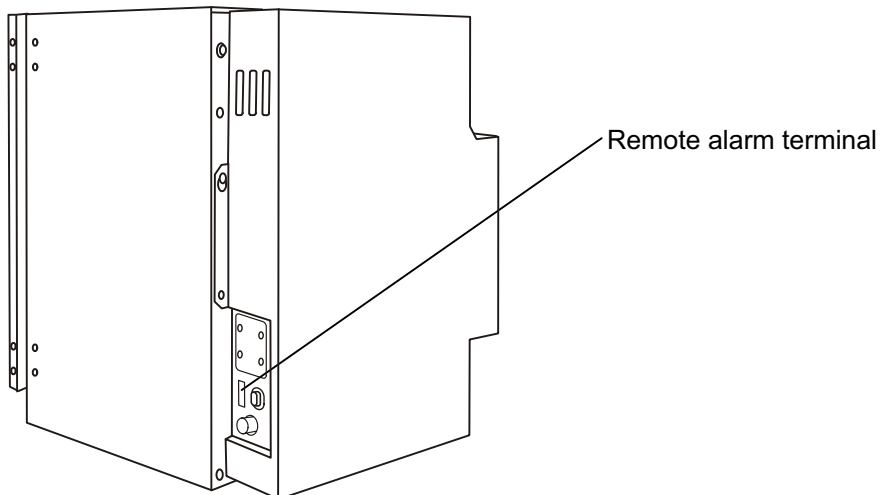

The remote alarm terminal is a contact output.

Normal	:	OPEN
Abnormal , blackout	:	CLOSE
Contact capacity	:	DC 30V, 2A

Note:

- When the power switch is OFF or the power failure condition, the contact output is CLOSE.
- The remote alarm cannot be silenced by pressing the alarm buzzer stop key (BUZZER) since the remote alarm is not conjunct with the BUZZER key. (The contact output is kept even though the remote alarm is silenced by pressing buzzer stop key (BUZZER).

REMOTE ALARM

MAX DC30V 2A

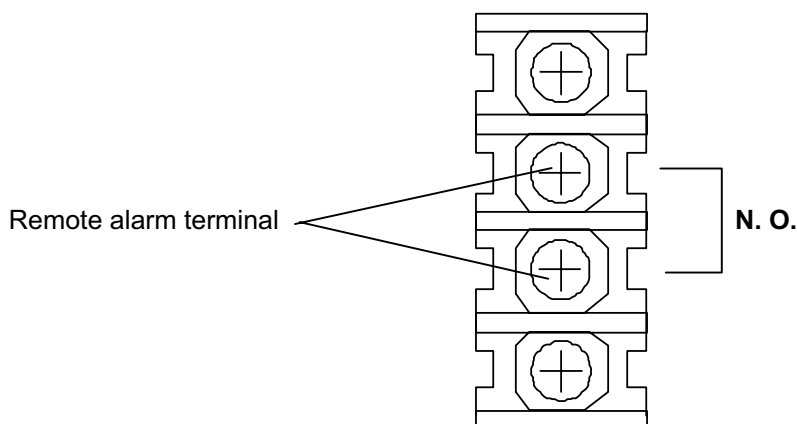

INSTALLATION

Installation site

To operate this unit properly and to obtain maximum performance, install the unit in a location with the following conditions:

Note: The ambient temperature must be at least 5°C lower than the set temperature.

1. A location not subjected to direct sunlight or direct air flow from an air conditioner

2. A location with clean air and adequate ventilation (Small and sealed room is not recommended.)

WARNING

If the unit is used in a small confined room, the CO₂ density level in the air could rise and may be harmful to humans.

Ventilate a room air occasionally when using CO₂ gas for control. The gas density will increase in an enclosed small room and high level of gas density can be hazardous to health. In addition, avoid inhaling the chamber air directly when opening the door if CO₂ gas is used.

3. A location away from heat generating sources

4. A location with a sturdy and level floor

WARNING

Install the unit on a sturdy floor. If the floor is not strong enough or the installation site is not adequate, this may result in injury from the unit falling or tipping over.

Select a level and sturdy floor for installation. This precaution will prevent the unit from tipping. Improper installation may result in water spillage or injury from the unit tipping over.

5. A location without flammable or corrosive gas

WARNING

Never install the unit in a flammable or volatile location. This may cause explosion or fire.

Never install the unit where acid or corrosive gases are present as current leakage or electric shock may result due to corrosion.

6. A location not prone to high humidity

WARNING

Do not use the unit outdoors. Current leakage or electric shock may result if the unit is exposed to rain water.

Never install the unit in a humid place or a place where it is likely to be splashed by water. Deterioration of the insulation may result which could cause current leakage or electric shock.

INSTALLATION

Prevent contamination

To prevent contamination of the chamber, select an appropriate location for installation as well as ensuring the complete disinfection of the chamber components.

1. Avoid hot and humid location

Avoid location with high temperature and/or humidity as the presence of bacteria in the air is greater than in the normal environment.

2. Avoid drafty location and location with many passers-by

Avoid locations near doors, air conditioners, fans, etc., where slight breezes can facilitate the entry of bacteria into the chamber.

3. Installation in a sterile room

To promote efficient cultivation, it may be best to install the unit in a sterile room.

4. Use clean containers

Contamination is often caused by containers such as Petri dishes or bottles stored in the chamber introducing contamination. Always keep the containers clean.

Installation

1. Remove the packaging materials and tapes

Remove all transportation packaging materials and tapes. Open the doors and ventilate the unit. If the outside panels are dirty, clean them with a diluted neutral dishwashing detergent. (Undiluted detergent can damage the plastic components. For the dilution, refer to the instruction of the detergent.) After the cleaning with the diluted detergent, always wipe it off with a wet cloth. Then wipe off the panels with a dry cloth.

2. Adjust the leveling feet

Extend the leveling feet by rotating them counterclockwise so they contact the floor or bench. Ensure the unit is level.

3. Fix the unit

Two fixtures are attached to the rear of the frame. Fix the frame to the wall with these hooks and rope or chain.

4. Ground (earth)

WARNING

Use a power supply outlet with ground (earth) to prevent electric shock. If the power supply outlet is not grounded, it is necessary to install a ground by qualified engineers.

Never ground the unit through a gas pipe, water main, telephone line or lightning rod. Such grounding may cause electric shock in the case of an incomplete circuit.

BEFORE COMMENCING OPERATION

Sterilizing of chamber and attachments

Before first start-up of the unit, the chamber and internal attachments should be cleaned and sterilized as follows.

Note:

Take care not to damage the water level sensor or UV lamp (option) at the time of removal or replacement of attachments.

Do not clean the inside of the unit with a solution of disodium chlorate or other halogen-based solution because this may cause corrosion of metal surfaces.

1. Take out all attachment such as trays, humidifying pans, etc, from the chamber. Refer to page 28 and 29.
2. Clean all of the attachments with a diluted neutral dishwashing detergent and then wash out the detergent with distilled water. (Undiluted detergent can damage the plastic components. For the dilution, refer to the instruction of the detergent.)
3. Wipe the attachments with a gauze containing alcohol for sterilization and then wipe off with a dry gauze.
4. Wipe the inside wall of the chamber with a gauze containing alcohol for sterilization and then wipe off with a dry gauze.
5. Replace all attachments in the chamber.

Note:

Always insert the fan on the motor shaft surely. Improper insertion may cause poor performance.

6. Fill the humidifying pan with sterile distilled water.

BEFORE COMMENCING OPERATION

Connection of CO₂ gas cylinder

WARNING

Check the gas type and ensure that it is fit for the purpose. Make sure that all pipes are connected correctly and are not liable to become disconnected. Ensure that the gas pressure is set at the specified value. Improper connection of the gas pipe or use of incorrect gas pressure may result in leakage of CO₂ gas. **Elevated level of CO₂ gas can be hazardous to health and may lead to asphyxiation and risk of death.** If restricted ventilation is suspected, then other methods of ensuring a safe environment must be considered. These may include atmosphere monitoring and warning devices. Keep proper gas pressure to avoid gas leak.

Use a liquefied CO₂ gas cylinder, not a siphon (dip tube) type. The CO₂ gas should be 99.5% or more pure.

1. Install a pressure regulator (optional accessory MCO-100L) on the cylinder. Use a regulator rated at 25MPaG (250kgf/cm²G, 3600psiG) on the primary side and 0.2MPaG (2.0kgf/cm²G, 30psiG) on the secondary side.
2. Using the gas supply pipe provided, connect the pressure regulator to the CO₂ inlet located at the rear left hand side of the CO₂ incubator.
3. Set the CO₂ pressure on the secondary side to 0.03MPaG (0.3kgf/cm²G, 4.3psiG) (at gas injection). Excessive pressure may cause disconnection of internal pipes inside the CO₂ incubator which will result in leakage of CO₂ gas into the atmosphere. **Elevated level of CO₂ gas can be hazardous to health and may lead to asphyxiation and risk of death.** The repair of the incubator will be necessary if the internal pipe is disconnected.
4. Check that no gas is leaking at any point where the pipe connects with the CO₂ regulator or the CO₂ incubator.

Note:

- Never turn the gas pressure regulating handle of gas pressure regulator when replacing a gas cylinder. Turning the handle causes the change of gas pressure on the secondary side and needs readjustment. Excessive pressure on the secondary side may cause disconnection of internal pipes inside the CO₂ incubator. The repair of the incubator will be necessary if the internal pipe is disconnected.
- The incubator, including the gas supply pipes and services must be examined at frequent intervals to ensure they are safe. Ensure that items such as pipes are replaced if there is any sign of deterioration.

BEFORE COMMENCING OPERATION

Automatic CO₂ cylinder changeover

An automatic CO₂ cylinder changeover system (MCO-5GC) is available as an optional accessory. This kit switches the gas supply line when one CO₂ gas cylinder is empty.

Note: The installation of MCO-5GC should be implemented by a qualified service personnel.

After attachment of MCO-5GC, do the following:

1. Connect a CO₂ gas pipe to port A and B respectively. A connecting port for CO₂ gas pipe is located on the left back of the unit. (See page 11 and 12.)
2. Connect a CO₂ gas cylinder provided with a gas pressure regulator to each gas pipe. See page 18, for the connection of the gas cylinder.
3. Open the valve of each gas cylinder.
4. Check that the CO₂ gas supply line indicator on the control panel is lit by pressing the switching key.
5. Select a CO₂ gas supply line (A or B).
6. When one cylinder is empty, the indicator is flashed, buzzer sounds (remote alarm is activated), and "E01" is displayed alternately on the control panel while the gas supply line is switched to other one. To silence the buzzer, press the BUZZER key.
7. Replace the empty CO₂ gas cylinder.

Note: Exercise caution when handling empty CO₂ gas cylinders as some gas can still be left in the cylinder.

This kit MCO-5GC detects that no more CO₂ gas exists in a cylinder when the CO₂ density in the chamber is not increased for a while after opening of CO₂ gas valve in the unit and switches the gas supply line. The switching of supply line can be caused by some other reasons; blocking or restricting of gas tube, reduction of CO₂ gas pressure, or improper opening of CO₂ gas cylinder, in spite of gas quantity in the cylinder. Therefore, always check the gas quantity in the cylinder prior to disconnection.

OPERATING INSTRUCTIONS

Set of chamber temperature and CO₂ density

Table below shows the basic procedure for setting the chamber temperature and CO₂ density. The upper limit alarm temperature setting is also shown in the table. Perform key operations in the sequence indicated in the table. The example in the table is based on the assumption that the desired temperature is 37°C and CO₂ density is 5%. Adjustment of the upper limit regulator should be executed after the chamber temperature reaches the stable condition.

Note: The unit is set at the factory so that the chamber temperature is 37°C and CO₂ control is 0%.

Allow at least 8 hours until the next setting after setting of desired chamber temperature and setting CO₂ density to 0%, at the time of first start-up or start-up after no use for long term.

Basic operation sequence (Example: Chamber temperature; 37°C, CO₂ density; 5%)

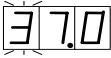
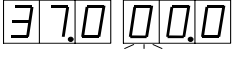
	Description of operation	Key operated	Indication after operation
1	Turn the power switch ON.		The current chamber temperature is displayed in temperature indicator.
2	Press SET key.	SET	The left digit is flashed. 
3	By pressing digit shift key and numerical value shift key, set the figure to 37.0.	▶▶	When pressed, the changeable digit is shifted.
		▲	When pressed, the figure of settable digit changes.
4	Press ENT key.	ENT	Set temperature is memorized. Left digit in CO ₂ density indicator is flashed. 
5	By pressing digit shift key and numerical value shift key, set the figure to 05.0.	▶▶	When pressed, the changeable digit is shifted.
		▲	When pressed, the figure of settable digit changes.
6	Press ENT key.	ENT	Set CO ₂ density is memorized.
7	(Executed after the chamber temperature reaches the stable condition) Adjust upper limit regulator so that the alarm temp. is 1°C higher than chamber temperature.		In CO ₂ density indicator, HI is displayed. In temperature indicator, upper limit temp. is displayed. The upper limit temp. can be changed by turning upper limit regulator.
8	Press ENT key.	ENT	This is the end of set mode and the indicators display current temperature and CO ₂ density.

Note:

- In each set mode, if the change of the setting is not necessary, pressing SET key skips to next set mode.
- When the CO₂ density is set to 00.0, the control is OFF regardless of chamber density.
- The upper limit temperature set value will change when the regulator is turned even if the unit is not in set mode, because the alarm circuit is an independent circuit.
- In each set mode, the indicator returns to the current temperature and CO₂ density display mode automatically when 90 seconds has passed without any key operation.

OPERATING INSTRUCTIONS

UV lamp

The clauses below are applicable when an optional UV system kit MCO-18UVS2 is installed.

A UV lamp is located inside the rear duct to sterilize the water in the humidifying pan and air circulating in the chamber.

Following shows precautions and instructions about the UV lamp.

- The UV light is exposed only to the inside of the duct and the humidifying pan cover when all chamber components are installed properly.
- During cultivation, ensure all components are located adequately and never turn on the UV light without the humidifying pan cover.
- Even if the unit is operating without turning on the UV lamp, the humidifying pan cover should be installed properly. An operation without pan cover will affect the temperature distribution and humidify recovery.
- When checking the UV lamp operation, open the outer door and push the door switch with the inner door closed. The visible blue light can be checked under the humidifying pan cover. The UV light is harmful to eyes. Never turn on the UV light with the inner door or humidifying pan cover opened.
- The UV lamp is ON for a predetermined period after the outer door is closed, or every 12 hours when the outer door is not opened more than 12 hours continuously. The period of factory setting is 5 minutes. The period can be changed when necessary as shown in the page 22.
- The recommended timing of lamp replacement (the ratio of UV output is less than 70% of initial value) is when the accumulated ON time is over about 1,000 hours. The blink of the UV indicator when the UV lamp is OFF means the accumulated time has exceeded about 1,000 hours and recommends the replacement of the lamp. When replacing the UV lamp, contact Sanyo sales representative or agent.
- E18 is displayed on the temperature indicator when the UV lamp is burned out. In this case, replace the lamp immediately. At the time of replacement, also replace the glow starter (Type; FG-7P). For the replacement of UV lamp and glow starter, contact Sanyo sales representative or agent.



OPERATING INSTRUCTIONS

Change of setting for UV lamp ON period

The clauses below are applicable when an optional UV system kit MCO-18UVS2 is installed.

Follow the procedure below when changing the setting for UV lamp ON period.

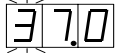
Basic operation sequence (Example: change of UV lamp ON period from 5 minutes to 3 minutes)

	Description of operation	Key operated	Indication after operation
1	Press CAL key for 5 seconds.	CAL	The left digit in the temperature indicator is flashed. 
2	By pressing digit shift key and numerical value shift key, set the figure to F01.	▶▶	When pressed, the changeable digit is shifted.
		▲	When pressed, the figure of settable digit changes.
3	Press ENT key.	ENT	The current setting is displayed in the CO ₂ density indicator. 
4	By pressing digit shift key and numerical value shift key, set the figure to 003.	▶▶	When pressed, the changeable digit is shifted.
		▲	When pressed, the figure of settable digit changes.
5	Press ENT key.	ENT	Set value is memorized and the display return to normal display mode.

- The available set range for the UV lamp is between 0 and 30 minutes (000 to 030). When set to 000, the UV lamp is not turned on.
- The UV lamp is turned off during ON period when the outer door is opened. After closing the outer door, the lamp turns on during predetermined period.
- Condensation will occur and/or temperature distribution may be affected due to the heat of the UV lamp when the setting of the lamp operation is longer than 5 minutes or if only the outer door is opened repeatedly.
- For the replacement of UV lamp, contact Sanyo sales representative or agent.

Pressing CAL key for about 5 seconds leads the calibration mode. In the calibration mode, the calibration of temperature and CO₂ density is possible. Wrong key operation affects the basic performance. Never touch any other keys on the control panel in the event of pressing CAL key accidentally. After about 90 seconds, the unit returns to chamber temperature display mode automatically.

Operation after power failure



The set value is memorized by nonvolatile memory. Accordingly, the incubator resumes the operation with setting before power failure.

OPERATING INSTRUCTIONS



Key lock function

This unit is provided with a key lock function. When the key lock is ON, change of temperature or CO₂ density setting through the key pad is not available.

Note: The key lock is set in OFF mode (L0) at the factory.

Display	Mode	Function
	Key lock is OFF	Enable to change of temperature and CO ₂ setting
	Key lock is ON	Disable to change of temperature or CO ₂ setting

Procedure for key lock setting (change from key lock OFF to key lock ON)

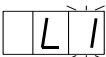
	Description of operation	Key operated	Indication after operation
1		----	The current chamber temperature and CO ₂ density are displayed.
2	Press digit shift key for 5 seconds.		L0 is displayed in the temperature indicator. 
3	Press numerical value shift key and scroll the figure to 1.		When pressed, the figure of settable digit changes. 
4	Press ENT key.	ENT	The key lock is set to ON. The current chamber temperature is displayed.

Note:

- The key lock function is available for temperature and CO₂ density setting.
- To cancel the key lock, set to L0 in the above procedure.

OPERATING INSTRUCTIONS

Water level sensor

This unit is provided with a water level sensor for the humidifying pan. The sensor is set in active position with respect to the installation of the humidifying pan. Take care not to damage the sensor at the time of removal or installation of the humidifying pan.

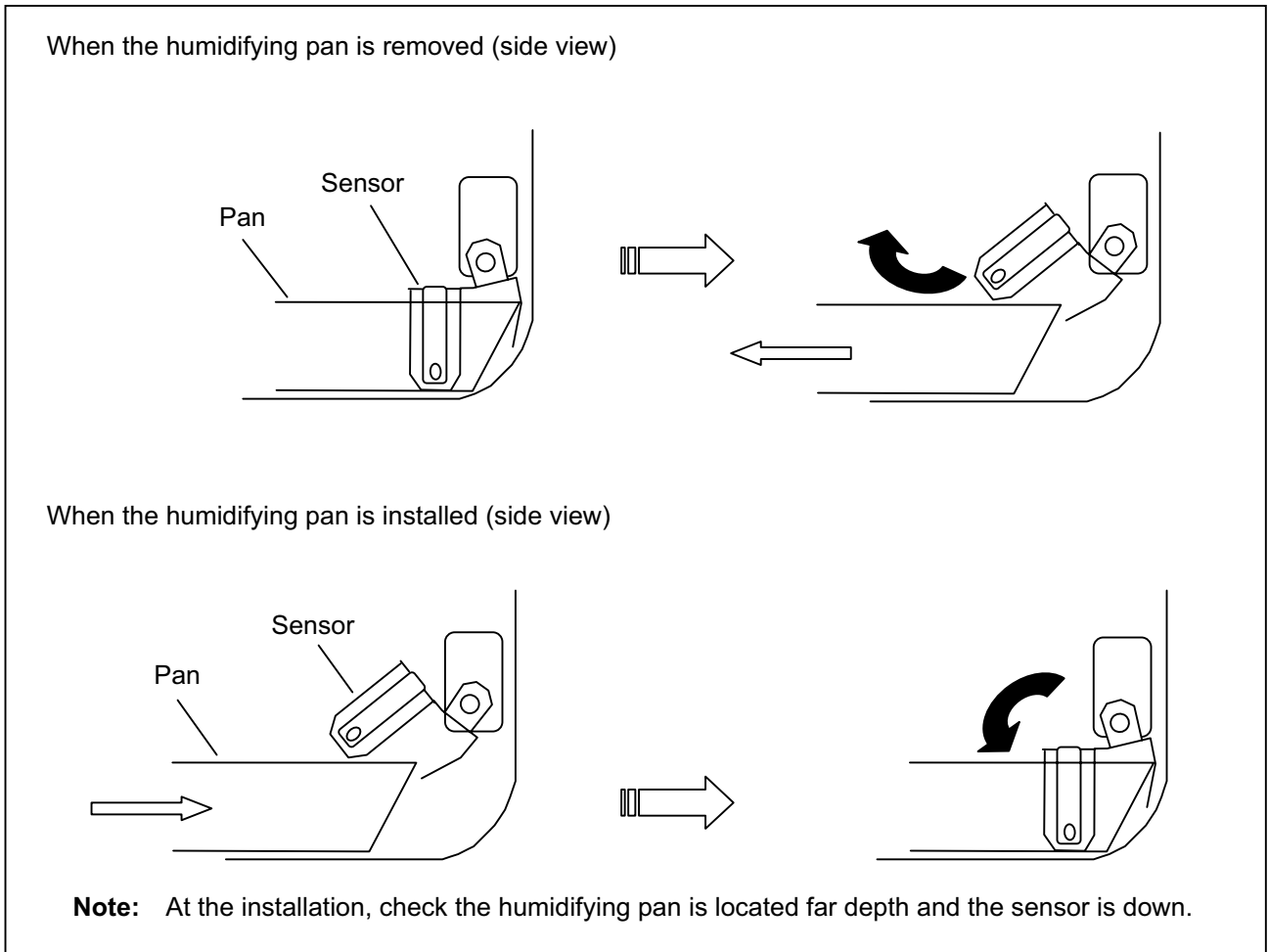

Note:

- Lift the sensor before installing the humidifying pan if the sensor is in lower position after maintenance.
- At the time of installation of humidifying pan, check that the pan is set properly and sensor is down in the pan. The water level alarm lamp (RH PAN) blinks if the sensor is not down completely. In this case, set the pan again in adequate location.
- Use an alcohol for sterilization when cleaning the sensor, taking care not to stress the lead wire.
- The sensor detects the water level every 30 minutes. In addition, detection is executed after operation of the outer door. It takes several seconds to detect the water level. Therefore, the water level alarm lamp may flash a few times after the outer door is closed with the humidifying pan filled sufficiently.

ALARMS & SAFETY FUNCTIONS

This unit has the alarms and safety functions shown in table below, and also self diagnostic functions.

Alarms and safety functions

Alarm & Safety	Situation	Indication	Buzzer	Safety operation
Upper limit temperature alarm	If the chamber temperature exceeds the upper limit alarm temperature set value.	Over heat lamp lights. E12 or E16 and chamber temperature are displayed alternately.	Continuous tone	Heater OFF Remote alarm
Automatic set temperature alarm	If the chamber temperature deviates from the set temperature by $\pm 1^{\circ}\text{C}$ or more.	All digits on the temperature indicator blink.	Intermittent tone with 15 minutes delay.	Remote alarm with 15 minutes delay
Automatic set CO ₂ density alarm	If the chamber CO ₂ density deviates from the set value by $\pm 1\%$ or more.	All digits on the CO ₂ density indicator blink.	Intermittent tone with 15 minutes delay.	Remote alarm with 15 minutes delay
Auto-return	When there is no key pressing in each setting mode for 90 seconds.	Normal display mode.	-----	The setting mode is canceled.
Key lock	When the key lock is "ON".	-----	-----	The setting is disabled.
CO ₂ gas cylinder empty	If the CO ₂ density does not increase when the gas valve is opened.	E01 is displayed alternately with the temperature on the temperature indicator.	Intermittent tone	Remote alarm
Gas line changeover	When the gas supply line is switched. (only when MCO-5GC is installed)	E01 is displayed alternately with the temperature on the temperature indicator. Gas supply line indicator blinks.	Intermittent tone	Gas supply line is altered. Remote alarm
Chamber temperature sensor abnormality	If the temperature sensor is disconnected.	E05 is displayed alternately with the temperature on the temperature indicator.	Intermittent tone	Heater OFF Remote alarm
	If the temperature sensor is short circuited.	E06 is displayed alternately with the temperature on the temperature indicator.		
Ambient temperature sensor abnormality	If the ambient temperature sensor is disconnected.	E09 is displayed alternately with the temperature on the temperature indicator.	Intermittent tone	Remote alarm
	If the ambient temperature sensor is short circuited.	E10 is displayed alternately with the temperature on the temperature indicator.		
CO ₂ sensor abnormality	If the output voltage of the CO ₂ sensor is abnormal.	E11 is displayed alternately with the temperature on the temperature indicator.	Intermittent tone	CO ₂ valve close. Remote alarm
Main heater abnormality	If the upper limit alarm temperature alarm operates, or if the main heater is open circuit, or the main heater relay short circuit.	E12 is displayed alternately with the temperature on the temperature indicator.	Intermittent tone	Remote alarm
Bottom heater abnormality	If the bottom heater goes open circuit, or the bottom heater relay short circuit.	E13 is displayed alternately with the temperature on the temperature indicator.	Intermittent tone	Remote alarm
Door heater abnormality	If the door heater goes open circuit, or the door heater relay short circuit.	E14 is displayed alternately with the temperature on the temperature indicator.	Intermittent tone	Remote alarm
Disconnection of sensor for each heater	If the relay of main heater, bottom heater or sensor box heater goes open circuit.	E16 is displayed alternately with the temperature on the temperature indicator.	Intermittent tone	Remote alarm
Low humidifying water	If the water in the pan is about 0.8 liter.	RH PAN lamp blinks.	-----	-----
UV lamp failure	[When MCO-18UVS2 is installed] When the UV lamp is burned out.	E18 is displayed alternately with the temperature on the temperature indicator.	Intermittent tone	Remote alarm
Recommendation of new UV lamp	[When MCO-18UVS2 is installed] The accumulated ON time is over about 1,000 hrs.	UV indicator blinks when UV lamp is OFF.	-----	-----

- The alarm can be canceled by pressing the BUZZER key, but the remote alarm cannot be silenced. And the upper limit temperature alarm cannot be silenced with the BUZZER key.
- E01 is cleared automatically when the gas is connected correctly and the buzzer is silenced with the BUZZER key. When MCO-5GC is installed, press BUZZER key to silence the alarm after changeover of gas supply line.
- If one of E05 to E17 (except for E12, E13, and E14) is displayed, consult with a Sanyo sales representative or agent.



SETTING OF ALARM RESUME TIME

The alarm buzzer is silenced by pressing BUZZER key on the control panel during alarm condition. The buzzer will be activated again after certain suspension if the alarm condition is continued. The suspension time can be set by following the procedure shown in the table below.

The example in the table is based on the assumption that the desired duration is 20 minutes.

Note: The duration is set in 30 minutes at the factory.

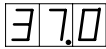
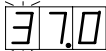
Table Changing procedure for alarm resume time (Ex: change from 30 minutes to 20 minutes)

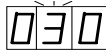
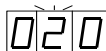
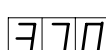
	Description of operation	Key operated	Indication after operation
1		----	The current chamber temperature is displayed. 
2	Press CAL key for 5 seconds.	CAL	The left digit is flashed. 
3	Set the figure to F25 with the digit shift key and numerical value shift key.	▶▶	The settable digit is shifted.
		▲	When pressed, the figure of settable digit changes. 
4	Press ENT key.	ENT	The current setting is displayed. The middle digit is flashed. 
5	Set the figure to 020 with the numerical value shift key.	▲	When pressed, the figure of settable digit changes. 
6	Press ENT key.	ENT	The setting is memorized and the current chamber temperature is displayed. 

- The settable alarm resume time are 0, 10, 20, 30, 40, 50, or 60 minutes (The setting is 000, 010, 020, 030, 040, or 060 respectively). The buzzer would not reset if the reset time is set in 000.
- The set mode returns to the temperature display mode automatically when 90 seconds has passed without any key operation. In this case, any setting before pressing ENT key is not memorized.

ROUTINE MAINTENANCE

WARNING

Always disconnect the power supply to the unit prior to any repair or maintenance of the unit in order to prevent electric shock or injury.

Ensure you do not inhale or consume medication or aerosols from around the unit at the time of maintenance. These may be harmful to your health.

CAUTION

Always put on dry gloves to protect hands at the time of maintenance. Failure to use gloves may result in cuts or abrasions from any sharp edges or corners.

Sterilizing of chamber and attachments

When the chamber of the unit is contaminated, the chamber and internal attachments should be cleaned and sterilized as follows.

Note:

Take care not to damage the water level sensor or UV lamp(option) at the time of removal or replacement of attachments.

Do not clean the inside of the unit with a solution of disodium chlorate or other halogen-based solution because this may cause rust.

1. Take out all trays and the humidifying pan from the chamber.
2. Remove ducts, side support (right and left side), and the fan as shown in the figures on page 28 and 29.
3. Clean all the attachments with a diluted neutral dishwashing detergent and then rinse away the detergent with distilled water. (Undiluted detergent can damage the plastic components. For the dilution, refer to the instruction of the detergent.)
4. Wipe the attachments with a gauze containing alcohol for sterilization and then wipe off with a dry gauze.
5. Wipe the inside wall of the with a gauze containing alcohol for sterilization and then wipe off with a dry gauze.
6. Replace all attachments in the chamber.

Note:

Always insert the fan on the motor shaft surely. Improper insertion may cause poor performance.

7. Fill the humidifying pan with sterile distilled water.

ROUTINE MAINTENANCE

Removal of attachments

Note:

Take care not to damage the UV lamp (when an optional UV system kit MCO-18UVS2 is installed) or water level sensor at the time of removal or replacement of attachments.

1. Close the valve of the gas cylinder and turn off the power.
2. Open the outer and inner door.
3. Pull out the all trays. See Fig. 1
4. By lifting up the humidifying pan cover, unhook it at the rear and remove the cover as shown in Fig. 2.
5. Take out the humidifying pan. See Fig. 3
6. Loosen and remove the screw fixing the clamp and remove the clamp. See Fig. 4 and Fig. 5.
7. Remove all tray supports on the right and left side by lifting up the front side. See Fig. 6.

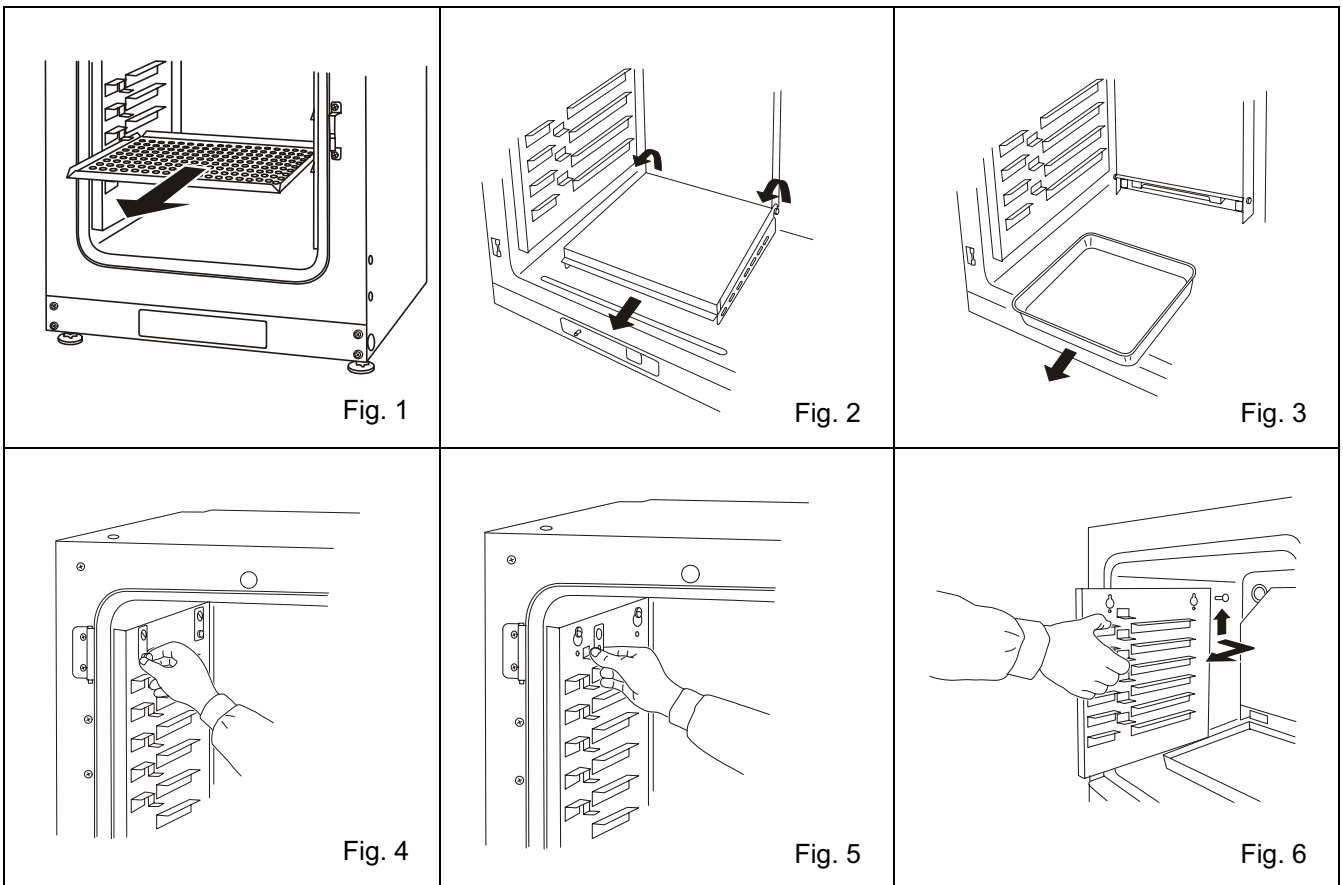

ROUTINE MAINTENANCE

8. To remove the rear duct, lift it up as shown in Fig. 7.

9. To removing the circulating fan, pull out the spring and then pull the fan. See Fig. 8.

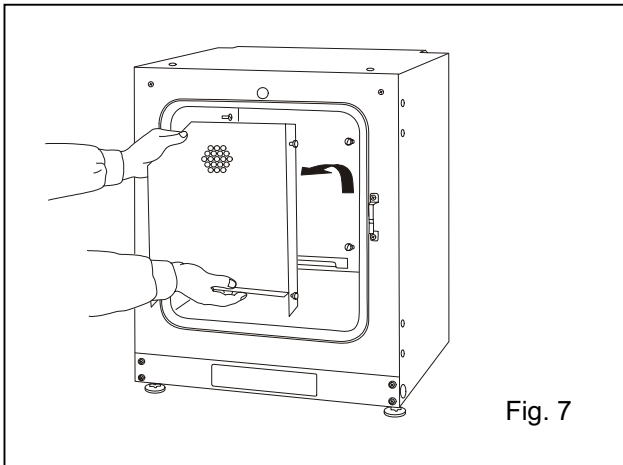

Fig. 7

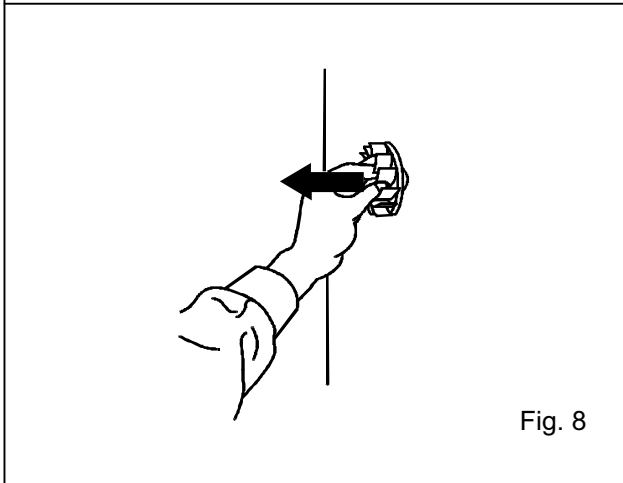
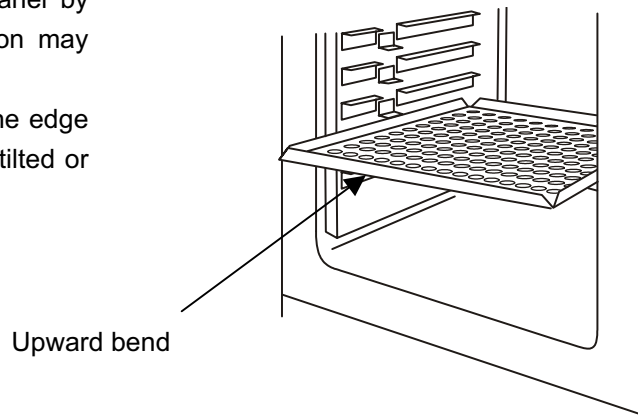

Fig. 8

10. Replace all attachments in the chamber with the reversed order mentioned above.

Note:

- Always insert the fan on the motor shaft surely. Check that the fan does not hit the rear panel by turning the fan manually. Improper insertion may cause poor performance.
- As shown in the figure, set the shelf with the edge bent upward. Improper setting may cause a tilted or unstable condition.



ROUTINE MAINTENANCE

Filling the humidifying pan

To fill the humidifying pan or to replace the water in the humidifying pan, do the following:

1. Lift the front side of the humidifying pan cover as shown in Fig. 1.

2. Pull out the humidifying pan toward you. See Fig. 2.

3. Dispose of the water in the pan and wash it with a neutral dishwashing detergent. (Undiluted detergent can damage the plastic components. For the dilution, refer to the instruction of the detergent.) Then rinse the pan with distilled water sufficiently. Finally, wipe the pan with a soft cloth and alcohol for disinfection.

4. Wipe off the bottom of the chamber completely.

5. Place the pan under the pan cover and pour the sterile distilled water (about 1.5 liters) into it. See Fig.3. Make sure that the water is pre-heated at 37°C.

6. Push the pan into its correct position and replace the cover over the pan. Close the inner and outer door.

7. Check that the water level alarm lamp on the control panel is off.

Note:

- The sterile water filled in the humidifying pan should be pre-heated at 37°C. Cold water lowers the chamber temperature.
- Replace the water in the pan by the above procedure when the water level alarm lamp blinks.

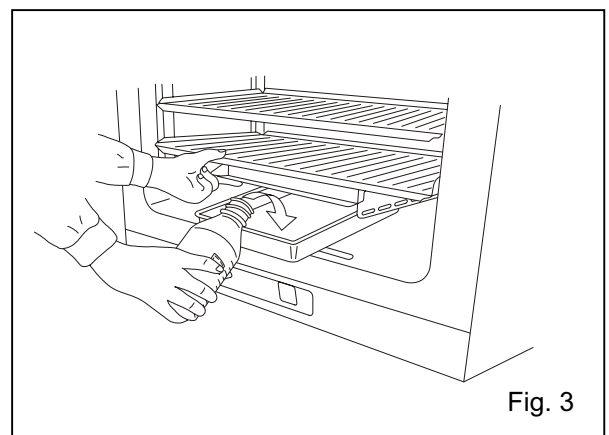
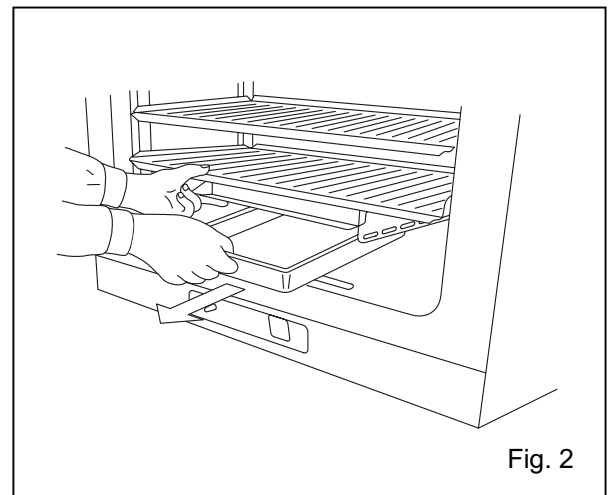
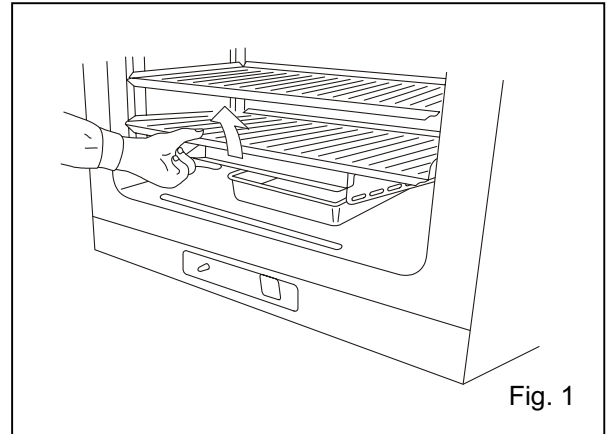

CALIBRATION

Temperature calibration

1. Press the CAL key for approximately 5 seconds.
2. The third digit of the temperature indicator flashes, and the CO₂ density indicator goes out.
3. Set the present correct temperature with the ►► key and ▲ key, then press the ENT key.
4. The unit automatically reverts to the display mode.

[Example]

If the displayed chamber temperature is 37.0°C (set value) and the actual temperature is 36.8°C.

1. Press the CAL key for about 5 seconds.
2. The “3” on the temperature indicator flashes, and the CO₂ density indicator goes out.
3. Adjust the set value to the actual value of 36.8°C with the ►► key and ▲ key, then press ENT key.
4. The unit automatically reverts to the display mode.

Note:

It is important to accurately measure the temperature inside the unit when performing temperature calibration. Particularly, the temperature gauge used must have an accuracy of 0.5 Class or better. The temperature must be measured at several points.

The temperature setting must not change by more than $\pm 1.0^{\circ}\text{C}$ during calibration. If it exceeds this, an error tone is emitted, the input data is ignored, and the unit reverts to the display mode. Consequently, if it is necessary to change the temperature by more than 1.0°C , perform calibration in several stages over a period of time.

CO₂ calibration

[Zero setting]

Zero setting should be done when CO₂ has not been injected yet and the stable condition (about 8 hours) of temperature/humidity inside the unit has been attained.

1. Press the CAL key for 5 seconds.
2. The third digit on the temperature indicator flashes, and the CO₂ density indicator goes out.
3. Press the CAL key once again.
4. The third digit on the CO₂ density indicator flashes, and the temperature indicator goes out.
5. Set 00.0 with the ►► key and ▲ key, then press the ENT key.
6. The unit automatically reverts to the display mode.

Span setting

Span setting should be done under stable condition of temperature, humidity, and CO₂ density.

1. Press the CAL key for about 5 seconds.
2. The third digit on the temperature indicator flashes, and the CO₂ density indicator goes out.
3. Press the CAL key once again.
4. The third digit on the CO₂ density indicator flashes, and the temperature indicator goes out.
5. Set the present correct CO₂ density with the ►► key and ▲ key, then press the ENT key.
6. The unit automatically reverts to the display mode.

Note:

This calibration is available when the setting of CO₂ density is 2% or more.

[Example]

For an internal CO₂ density of 5.0% (setting) and a measured value of 4.5%.

1. Press the CAL key for about 5 seconds.
2. The third digit on the temperature indicator flashes, and the CO₂ density indicator goes out.
3. Press the CAL key once again.
4. The third digit on the CO₂ density indicator flashes, and the temperature indicator goes out.
5. Set the present correct CO₂ density (4.5%) with the ►► key and ▲ key, then press the ENT key.
6. The unit automatically reverts to the display mode.

TROUBLESHOOTING

If the unit malfunctions, check out the following before calling for service.

The unit does not operate at all

- The unit is not plugged correctly into a power outlet.
- The circuit breaker at the power source is active or a power failure has occurred.
- The power supply code is connected to the port attached on the rear of the cabinet.

The key operation is disabled

- The key lock function is set in ON mode.

If the alarm function operates

[At the beginning of operation]

- The chamber temperature is not equal to the set value.
- The chamber CO₂ density is not equal to the set value.
 - a. The secondary pressure of the pressure regulator is not equal to the set value (0.03MPaG, 0.3kgf/cm²G, 4.3psiG).
 - b. The tube is not connected securely between the pressure regulator and the unit.

[During operation]

- The upper limit alarm temperature is not set at least 1°C higher than the set chamber temperature.
- The set temperature value was changed, or the door was left open for a long period. Or a low temperature load was placed inside the unit. In this case, if the unit is left as it is, the alarm will eventually clear itself.
- The gas tube has slipped off or the gas leaks.
- The set value of the gas density was changed.
- The gas cylinder is empty. Check the primary pressure of the CO₂ cylinder once a week. (The primary pressure of less than 3.8MPaG (38kgf/cm²G) means a little gas in the cylinder. Replace the cylinder soon.

If the chamber temperature is not equal to the set temperature

- The ambient temperature must always be at least 5°C less than the set temperature.
- The outer door was closed while the inner door was left open.

If the gas density does not coincide with the set value

- The secondary pressure is not set to 0.03MPaG (0.3kgf/cm²G, 4.3psiG).
- The gas tube is clogged or chinked.
- The humidifying pan is not filled with sterile distilled water. (Always use sterile distilled water.)

If the chamber humidity does not rise

- The humidifying pan is not filled with sterile distilled water. (Always use sterile distilled water.)

If the CO₂ consumption is too much

- The door is opened frequently.
- There is any gas leakage at the connection or pin hole on the tube. It is recommended to replace the tube once a year.
- The gasket of the inner door is not completely sealed.
- The access port at the upper left corner is opened.

If normal cultivation cannot be done and chamber gas density is suspect

- The environment around the unit is not normal. The source of the contaminated gas is nearby.
- The unit is installed in an enclosed space.

If it takes much time to recover the gas density

- HEPA filter is provided in the gas piping. If it takes much time to recover the gas density even though the gas pressure is normal, it may be that dust on the HEPA filter prevents the gas flow. Consult the Sanyo dealer or agent.

TROUBLESHOOTING

If CO₂ gas is not injected

•The CO₂ gas is injected intermittently when the chamber CO₂ gas density pushes the set value, although the CO₂ density is controlled by ON-OFF method. And it is not abnormal that injection of CO₂ gas sometimes stops for about 15 seconds.

ENVIRONMENTAL CONDITIONS

This equipment is designed to be safe under the following conditions (based on the IEC 1010-1):

1. Indoor use;
2. Altitude up to 2000 m;
3. Ambient temperature 5°C to 35°C
4. Maximum relative humidity 80% for temperature up to 31°C decreasing linearly to 50% relative humidity at 40°C;
5. Mains supply voltage fluctuations not to exceed $\pm 10\%$ of the nominal voltage;
6. Other supply voltage fluctuations as stated by the manufacturer;
7. Transient overvoltages according to Installation Categories (Overvoltage Categories) II; For mains supply the minimum and normal category is II;
8. Pollution degree 2 in accordance with IEC 664.

DISPOSAL OF UNIT

WARNING

If the unit is to be stored unused in an unsupervised area for an extended period **ensure that children do not have access and doors cannot be closed completely.**

The disposal of the unit should be undertaken by appropriate personnel. Always remove doors to prevent accidents such as suffocation.

STACKED MODULE

This unit can be stacked by using the stacking kit. Following shows the procedure for stacking the unit. Consult with a Sanyo representative or agent prior to stacking procedure as such work involves dangers.

WARNING

Select a level and sturdy floor having enough strength for installation of stacked module.

Never stack 4 or more units.

Take care not to drop or tip over the unit when stacking as this can cause injury or damage of the unit.

1. Turn off the power switch and disconnect a plug of each unit.
2. The stacking plate A and B are contained in accessories bag.

Note:

When stacking the unit, 2 stacking plates A and 2 stacking plates B are necessary.

3. Check that the lower unit is level.
4. Remove two caps at 2 locations on the top front of under unit, and apply the protective sticker enclosed with the unit at each corner on the top of the lower unit to avoid scratches or damage(Fig.A).
5. Fix the stacking plate A at 2 locations on the top front of the lower unit by using 2 screws contained in accessories bag.
6. Remove the front panel on the upper unit by unscrewing the 4 fixing screws and then disconnect the wires and gas tube.
7. Stack the unit so that both units can be aligned straight. Also check the upper unit is level. If it is not level, keep the unit even by adjusting the leveling legs.
8. Secure the upper unit with the stacking plate A and 2 screws contained in accessories bag.
9. Remove 2 screws on the above right and left on the rear side of the lower unit.
10. Remove 1 screw on the bottom right and left on the rear side of the upper unit.
11. Fix the stacking plate B at the right and left on the rear of the lower and upper unit with 3 screws removed in step 9 and 10.
12. Replace the front panel on the upper unit after connecting the wires and gas tube.
13. Repeat procedures from step 3. when stake more.
14. Fix the stacked unit to the wall with 2 stacking plate B on the rear of the top unit and rope or chain.

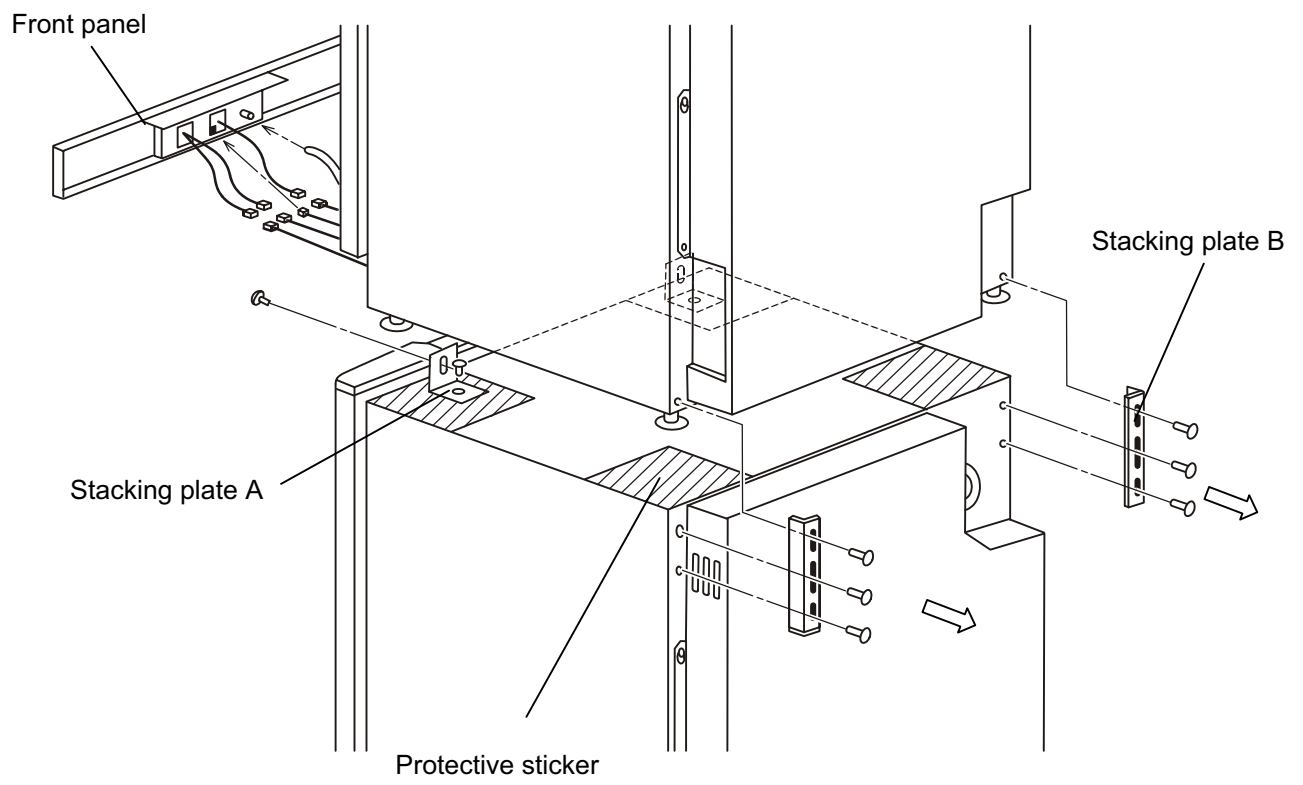

Fig.A <View from quarter rear side>

SPECIFICATIONS

Name	CO ₂ Incubator		
Model	MCO-5AC		
External dimensions	W480 x D548 x H568 (mm)		
Internal dimensions	W350 x D378 x H375 (mm)		
Interior volume	49 L		
Exterior	Acrylic finish baked on zinc galvanized steel		
Interior	Stainless steel containing copper (R corner structure)		
Outer door	Acrylic finish baked on zinc galvanized steel, Reversible support (selectable right or left-hand door)		
Inner door	Tempered glass		
Tray	Made of stainless steel containing copper (standard 3 trays , maximum 6 trays) W310 x D310 x H12 (mm), Maximum load; 4 kg/tray		
Access port	Inner diameter; 30 mm, On the back side		
Insulation	Rigid polyurethane foamed-in place (CFC-FREE)		
Heating system	Direct Heat & Air (DHA) jacket system		
Heater	180W		
Humidifying system	Natural evaporation with humidifying pan		
Temperature controller	PID control system		
Temperature display	Digital display		
CO ₂ controller	ON-OFF control system/TC sensor(direct detection in chamber)		
CO ₂ density display	Digital display		
Air circulation	Fan assisted		
Air filter	0.3 μ m, Efficiency; 99.97% or more		
Water level sensor	Optical type		
Alarm	High/Low temperature alarm, CO ₂ density alarm, Door alarm, Upper limit temperature alarm		
Remote alarm contact	Allowable contact capacity: DC 30 V, 2 A		
CO ₂ inlet connection	4 to 6 mm diameter tube		
CO ₂ inlet pressure	0.03MPaG (0.3kgf/cm ² G, 4.3psiG)		
Accessories	Power supply code ,3 trays, 1 gas tube, 1 humidifying pan, Stacking plate A and B, 4 protective stickers, 2 tube bands		
Weight	49 kg		
Optional accessory	Self-contained CO ₂ cylinder changeover system (MCO-5GC) Extra tray (MCO-30ST) , UV system kit (MCO-18UVS2), Roller base (MCO-5RB)		
Maximum power consumption	205 W		
Total maximum current	110 to 120 V, 60 Hz	220 V, 60 Hz	220 to 240 V, 50 Hz
	1.8 A	0.9 A	0.9 A

Note: Design or specifications will be subject to change without notice.

The ballast is not user replaceable part. Please contact a qualified service personnel.

PERFORMANCE

Temperature control range	Ambient temperature +5°C to 50°C (ambient temperature; 5°C to 35°C)
Temperature distribution	± 0.25°C* (ambient temperature; 25°C, setting; 37°C, 5%, no load)
Temperature variation	± 0.1°C (ambient temperature; 25°C, setting; 37°C, 5%, no load)
CO ₂ control range	0 to 20%
CO ₂ variation	± 0.15% (ambient temperature; 25°C, setting; 37°C, 5%, no load)
Chamber humidity	95 ± 5% R.H.
Maximum heat emission	740 kJ/h
Usable environment condition	Temperature; 5°C to 35°C, Humidity; equal or less than 80% R.H. (The designed performance may not be obtained when the ambient temperature is equal or less than 15°C)

Note: The unit with CE mark complies with EC directives 89/336/EEC, 93/68/EEC and 73/23/EEC.

* It is based on our measuring method.

⚠ CAUTION

Please fill in this form before servicing.

Hand over this form to the service engineer to keep for his and your safety.

Safety check sheet

1. Incubator contents : Yes No
Risk of infection: Yes No
Risk of toxicity: Yes No
Risk from radioactive sources: Yes No

(List all potentially hazardous materials that have been stored in this unit.)

Notes :

2. Contamination of the unit
- Unit interior Yes No
No contamination Yes No
Decontaminated Yes No
Contaminated Yes No
Others:

3. Instructions for safe repair/maintenance of the unit
- a) The unit is safe to work on Yes No
b) There is some danger (see below) Yes No

Procedure to be adhered to in order to reduce safety risk indicated in b) below.

Date :

Signature :

Address, Division :

Telephone :

Product name : CO ₂ incubator	Model : MCO-5AC	Serial number :	Date of Installation :
---	--------------------	-----------------	------------------------

Please decontaminate the unit yourself before calling the service engineer.

SANYO